

EC-TYPE EXAMINATION CERTIFICATE (MODULE B)

Certificate no.:
MEDB00006FA
Revision no.:
2

Application of: Directive 2014/90/EU of 23 July 2014 on marine equipment (MED), issued as "Forskrift om Skipsutstyr" by the Norwegian Maritime Authority. This Certificate is issued by DNV AS under the authority of the Government of Norway.

This is to certify:

that the **A' & 'B' Class divisions fire integrity: - 'A' class division**

with type designation(s)
A-60 Bulkhead SeaRox SL 620

issued to

Rockwool A/S
Hedehusene, Denmark

is found to comply with the Implementing Regulation (EU) 2024/1975 for
Item no. **MED/3.11a (Row 2 of 2)**

according to the following requirements:

SOLAS 74 Reg. II-2/3.2, SOLAS 74 Reg. II-2/9, IMO MSC/Circ.1120, IMO MSC.1/Circ.1434, IMO MSC.1/Circ.1616, IMO MSC.1/Circ.1621, IMO MSC/Circ.1120

Further details of the equipment and conditions for certification are given overleaf.

Date of issue: **2025-02-25**

Expiry date: **2030-02-24**

DNV local unit:
Denmark CMC

Approval Engineer:
Izabela Misztal

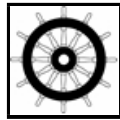

Notified Body
no.: **0575**



for **DNV AS**

Digitally Signed By:
Permoda, Jowita
on behalf of

Christine Mydlak-Röder
Head of Notified Body

A U.S. Coast Guard approval number will be assigned to the equipment when the production module has been completed and will appear on the production module certificate (module D, E or F), as allowed by the Agreement between the United States of America and the EEA EFTA states on the mutual recognition of Certificates of Conformity for Marine Equipment signed 17 October 2005, and amended by Decision No 1/2023 dated August 21st, 2023.



The mark of conformity may only be affixed to the above type approved equipment and a Manufacturer's Declaration of Conformity issued when the production-surveillance module (D, E or F) of Annex B of the MED is fully complied with and controlled by a written inspection agreement with a Notified Body. The product liability rests with the manufacturer or his representative in accordance with Directive 2014/90/EU.

This certificate is valid for equipment, which is conform to the approved type. The manufacturer shall inform DNV AS of any changes to the approved equipment. This certificate remains valid unless suspended, withdrawn, recalled or cancelled.

Should the specified regulations or standards be amended during the validity of this certificate, the product is to be re-approved before being placed on board a vessel to which the amended regulations or standards apply.

LEGAL DISCLAIMER: Unless otherwise stated in the applicable contract with the holder of this document, or following from mandatory law, the liability of DNV AS, its parent companies and their subsidiaries as well as their officers, directors and employees ("DNV") arising from or in connection with the services rendered for the purpose of the issuance of this document or reliance thereon, whether in contract or in tort (including negligence), shall be limited to direct losses and under any circumstance be limited to USD 300 000.

Product description

“A60 Bulkhead SeaRox SL 620”

composed of a structural steel bulkhead insulated with a layer of minimum 60 mm thick SeaRox SL 620 mineral wool (manufactured by Rockwool, nominal density 100-130 kg/m³) between the stiffeners and with a layer of minimum 25 mm thick insulation of the same type around the stiffeners.

The insulation is fixed to the bulkhead by means of Ø3 mm pins in combination with minimum Ø30 mm steel clips (spring washers). The distance between these pins is max. 300 mm.

Alternatively, a minimum layer of a 40 mm thick SeaRox ST 620 mineral wool (manufactured by Rockwool, nominal density 100 kg/m³) can be used around the stiffeners. The stiffeners cavity can be filled with one layer of 60 mm thick SeaRox SL 620 mineral wool (manufactured by Rockwool, nominal density 100 kg/m³).

For further details see documentation listed under Type Examination documentation.

Application/Limitation

Approved for use as a vertical fire retarding division of class A-60.

General application: fire on either side.

The insulation materials and adhesives used, have to be approved according to the Marine Equipment Directive and bear the Mark of Conformity. This requirement may also be applicable for surface materials used, if required by relevant rules and regulations.

Each product is to be supplied with its manual for installation and maintenance.

Type Examination documentation

Document No.	Rev.	Title
PGA10946A		Fire test report
PHA11188A	1	Assessment report
PHA10905A	1	Assessment report
PHA10905B	1	Assessment report

Tests carried out

Tested according to IMO 2010 FTP Code Part 3.

Marking of product

The product is to be marked with name and address of manufacturer, type designation, fire technical rating, the MED Mark of Conformity and USCG number if applicable (see first page).

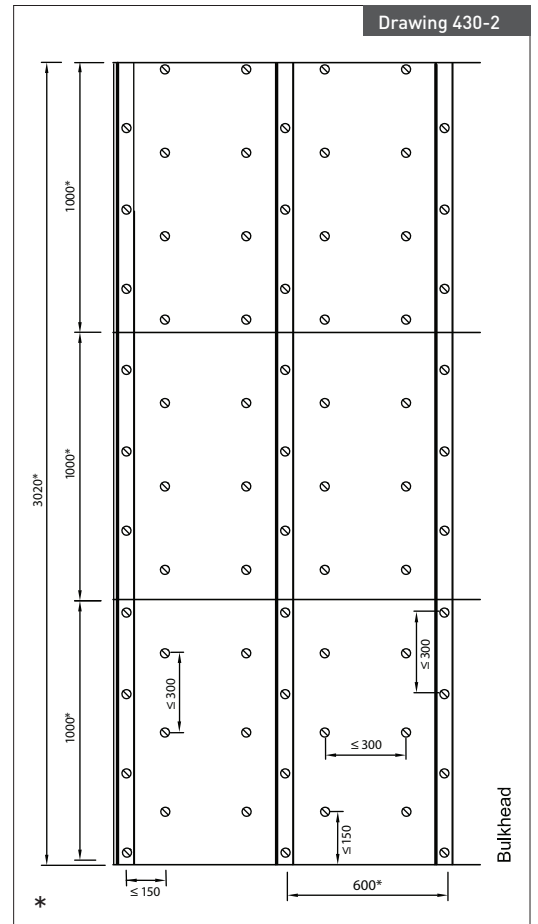
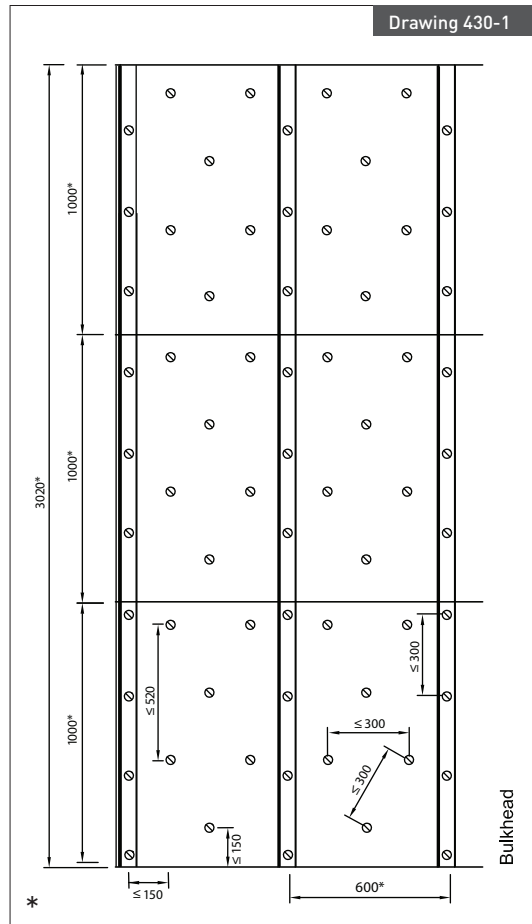
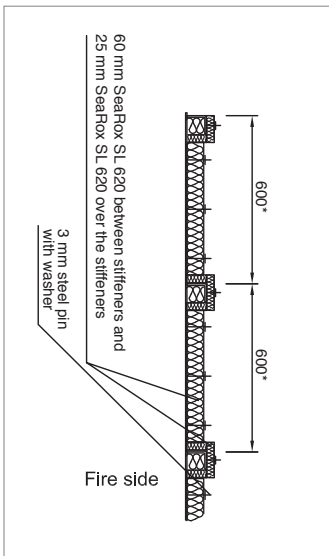

* Dimensions may vary depending on structural design and size of insulation slab.

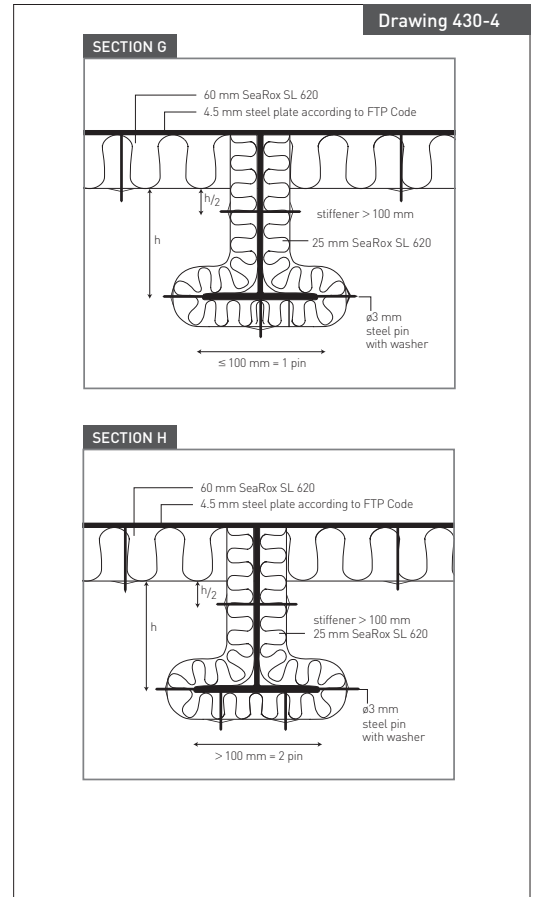
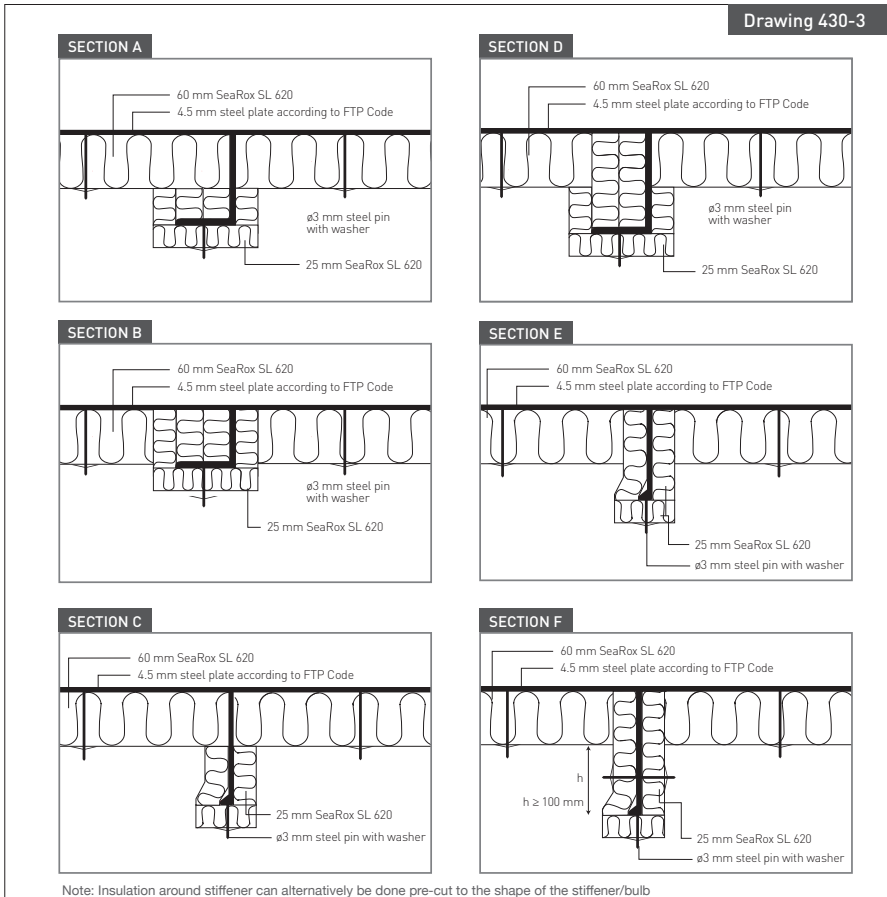

All measurements in mm

Date: 2017/02/03

Subject: A-60 Bulkhead SeaRox SL 620/ SeaRox SL 620

Assessment
Report Nos.:

ROCKWOOL®

TECHNICAL INSULATION